

WOOD SPECIES: _____

WOOD FINISH: _____

PLEASE ADVISE WOOD SPECIES AND WOOD FINISH. REFER TO C/S CATALOG FOR OPTIONS.

ACROVYN COLOR: _____

TOTAL LF REQ'D

TOTAL END CAPS REQ'D

TOTAL O/S CORNERS REQ'D

WOOD TO BE SUPPLIED IN VARIOUS LENGTHS THAT RANGE FROM 7' TO 12'

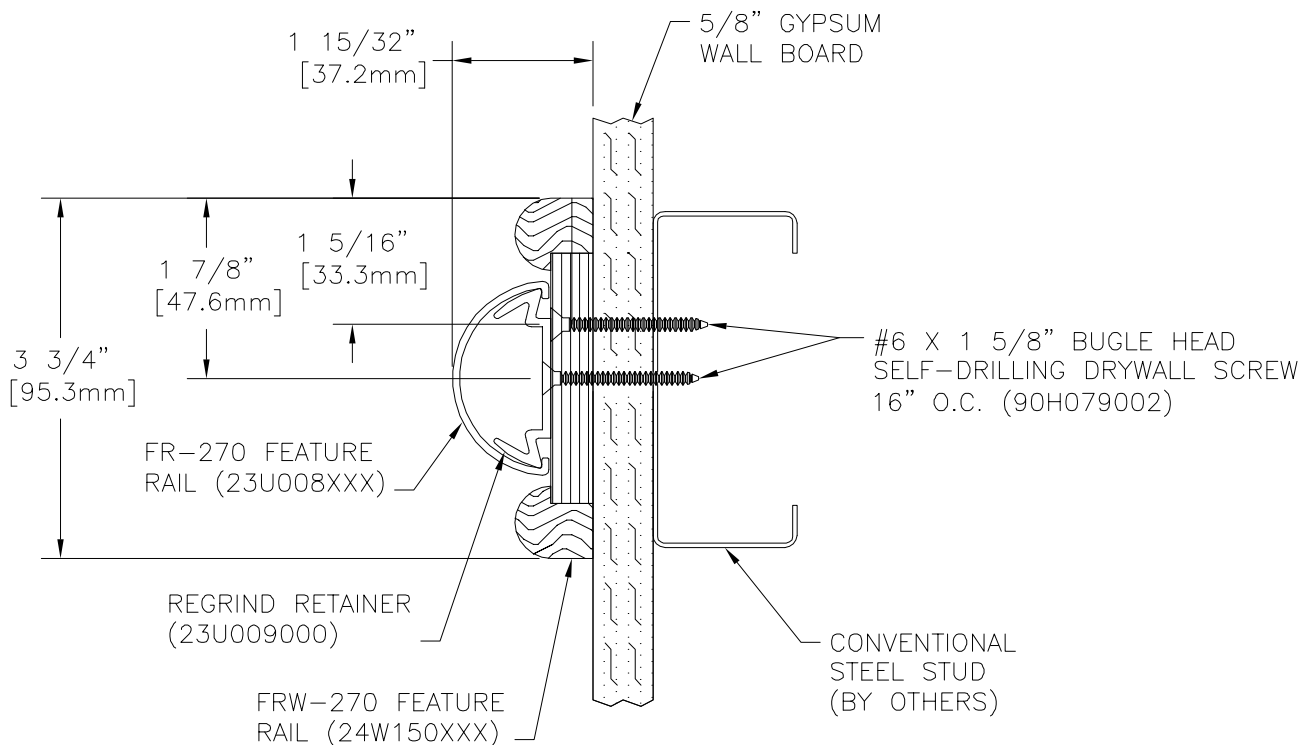

WALL CONDITION	SPECIFIED FASTENER	DRILL DIAMETERS		PART NUMBER
		WALL	RAIL	
CONCRETE/CONC. BLOCK	#10 X 1 1/2" PHILLIPS PAN HEAD SMS AF-6 ALLIGATOR ANCHORS	1/4"	N/A	90H189002 90H039004
STEEL STUD/GYPSUM WALL WOOD STUD/GYPSUM WALL	#6 X 1 5/8" BUGLE HEAD SELF-DRILLING DRYWALL SCREW	N/A	N/A	90H079002

FRW-270

C/S GROUP

MUNCY, PA 17756
VISTA, CA 92083
MISSISSAUGA, ONTARIO, CANADA

PROJECT:

REV. :

LOCATION:

F&F:

CUSTOMER:

SHEET OF

AGENT:

JOB NO.

DWG. BY:

DATE:

SECTION 10260
SUGGESTED SPECIFICATIONS

Part 1 - General

1.01 Summary

- A. This section includes the following types of wall protection systems:
 - 1. Accent Rails
- B. Related Sections: The following sections contain requirements related to this section:
 - 1. Handrails, Bumper Guards, Corner Guards, Accent Rails; refer to section 10260 "Wall and Corner Guards"
 - 2. Blocking in walls for fasteners; refer to section 09250 "Gypsum Board Systems"
 - 3. Wall Covering, Wall Panels, Door Protection; refer to section 09720 "Wall Coverings"

1.02 Reference

- A. American Society for Testing and Materials (ASTM)

1.03 Submittals

- A. General: Submit the following in accordance with conditions of contract and Division 1 specification section 01300.
- B. Product data and detailed specifications for each system component and installation accessory required, including installation methods for each type of substrate.
- C. Shop drawings showing locations, extent and installation details of crash rails. Show methods of attachment to adjoining construction.
- D. Samples for verification purposes: Submit the following samples, as proposed for this work, for verification of color, finish and end cap attachment and alignment.
 - 1. 12" (304.8mm) long sample of each model specified including end cap.
- E. Maintenance data for wall protection system components for inclusion in the operating and maintenance manuals specified in Division 1.

1.04 Quality Assurance

- A. Installer qualifications: Engage an installer who has no less than 3 years experience in installation of systems similar in complexity to those required for this project.
- B. Manufacturer's qualifications: Not less than 5 years experience in the production of specified products and a record of successful in-service performance.
- C. Single source responsibility: Provide all components of the wall protection system manufactured by the same company to ensure compatibility of color, texture and physical properties.

1.05 Delivery, Storage, and Handling

- A. Deliver materials to the project site in unopened original factory packaging clearly labeled to show manufacturer.
- B. Store materials in original, undamaged packaging in a cool, dry place out of direct sunlight and exposure to the elements. A minimum room temperature of 40°F (4°C) and a maximum of 100°F (38°C) should be maintained.
- C. Material must be stored flat.

1.06 Project Conditions

- A. Materials must be acclimated in an environment of 65° - 75°F (18° - 24°C) for at least 24 hours prior to beginning the installation.

- B. Installation areas must be enclosed and weatherproofed before installation commences.

Part 2 - Products

2.01 Manufacturers

- A. Construction Specialties, Inc., Muncy, Pa., Mississauga, Ontario.

2.02 Materials

- A. Solid Wood Components: Shall be manufactured from plain sawn, FAS grade hardwood, kiln dried to a moisture content of 6% to 10%. All wood components shall be factory finished. Wood components to be final coated with catalyzed, high solids, clear conversion varnish using a two-coat process. Finish shall be in accordance with specified AWI finish system. Coverage shall be a minimum of 3-5 mils. Gloss shall be measured on 60° gloss meter as per ASTM D523.
- B. Vinyl/acrylic: Extruded material should be high impact Acrovyn with shadow grain texture, minimum .078" (1.98mm) thickness. Chemical and stain resistance should be per ASTM D-1308 standards as established by the manufacturer. Colors to be indicated in the finish schedule from one of manufacturer's standard color range.
- C. Fasteners: All fasteners to be non-corrosive and compatible with wood. All necessary fasteners to be supplied by the manufacturer.

2.03 Accent Rails

- A. Vinyl/Acrylic and Wood Accent Rails: To be Renaissance by Construction Specialties. Surface mounted vinyl acrylic and solid wood accent rail. Attachment hardware shall be appropriate for wall construction.
 - 1. Model FRW-270 3-3/4" h (95mm) surface mounted accent rail consisting of a vinyl acrylic half round accent rail mounted within a wood base. Wood base to have factory milled end caps. Select from Maple, Beech, Ash or Oak woods. Standard finishes include Natural, Light Oak, Honey and Cherry. Custom woods and finishes available. Select vinyl acrylic rail from one of (60) Acrovyn solid colors or (161) Chameleon patterned colorways which include (5) woodgrains.

2.04 Fabrication

- A. General: Fabricate wall protection systems to comply with requirements indicated for design, dimensions, detail, finish and member sizes.
- B. Preassemble components in shop as much as possible to minimize field assembly.
- C. Fabricate components with wood joints lightly chamfered. Provide surfaces free of chipping, dents and other imperfections.

Part 3 - Execution

3.01 Examination

- A. Verification of conditions: Examine areas and conditions under which work is to be performed and identify conditions detrimental to proper or timely completion.
 - 1. Do not proceed until unsatisfactory conditions have been corrected.

3.02 Preparation

- A. Surface preparation: Prior to installation, clean substrate to remove dirt, debris and loose particles. Perform additional preparation procedures as required by manufacturer's instructions.

- B. Protection: Take all necessary steps to prevent damage to material during installation as required in manufacturer's installation instructions.

3.03 Installation

- A. Install the work of this section in strict accordance with the manufacturer's recommendations, using only approved mounting hardware, and locating all components firmly into position, level and plumb.
- B. Temperature at the time of installation must be between 65° - 75°F (18° - 24°C) and be maintained for at least 48 hours after the installation.

3.04 Cleaning

- A. General: Immediately upon completion of installation, clean rails and accessories in accordance with manufacturer's recommended cleaning method.
- B. Remove surplus materials, rubbish and debris resulting from installation as work progresses and upon completion of work.

3.05 Protection

- A. Protect installed materials to prevent damage by other trades. Use materials that may be easily removed without leaving residue or permanent stains.